

# CSE 677: Homework 4

(Due Date: Nov 28, Total: 40 points)

- (4 points) Consider the topology shown below. Suppose that all links have unit cost and that node *E* is the broadcast source. Using arrows like those shown in the figure below, indicate links over which packets will be forwarded using RPF, and links over which packets will not be forwarded, given that node *E* is the source. Note that ties can be broken arbitrarily.

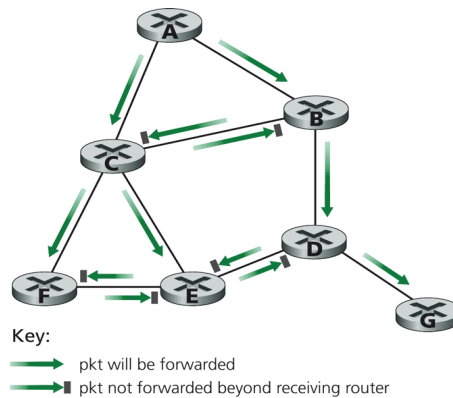

Reverse path forwarding

- (4 points) Consider the topology shown below, and suppose that each link has unit cost. Suppose node *C* is chosen as the center in a center-based broadcast routing algorithm. Assuming that each router uses its least cost path to node *C* to send join messages to *C*, draw the resulting center-based routing tree. Is the resulting tree a minimum-cost spanning tree? Justify your answer. Note that ties can be broken arbitrarily.

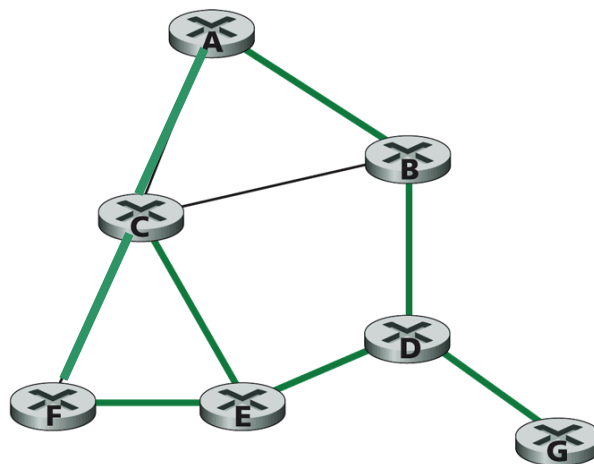

3. (4 points) Suppose the information content of a packet is the bit pattern **1010010110100101** and an even parity scheme is being used. Compute the parity bits for the case of a **2-dimensional** parity scheme if the bits are arranged in a 4X4 table? Assume that the first 4 bits are placed in the first row from left-to-right, the next 4 bits are placed in the next row, and so on.
4. (4 points) Consider a 2-dimensional parity scheme. Explain with reasons and examples.
  - (a) Can all 3 bit errors be detected? If not, are there any 3 bit errors that can be detected?
  - (b) Can all 3 bit errors be corrected? If not, are there any 3 bit errors that can be corrected?
5. (4 points) Consider the generator  $G=1110$  for computing CRC codes. Suppose  $D=10101010$ . What is the value of  $R$ ?
6. (4 points) Draw a waveform corresponding to the Manchester encoding for the bitstream **0 0 0 1**. Why is Manchester encoding better than sending data with no modulation, i.e., a high voltage for **1** and a low voltage for **0**?
7. (4 points) Consider a 100 Mbps 100 BaseT Ethernet. In order to have an efficiency of 0.5, what should be the maximum distance between two nodes? Assume that the frame length is 64 bytes (including the Ethernet header), the preamble is 64 bits, and the signal propagation speed is  $2 \times 10^8$  m/s.
8. (2 point) What is a supernet? What is the advantage of doing supernetting? (You can find the answers from Wikipedia).
9. (2 point) IS-IS is a popular intra-AS routing protocol. Write two similarities and two differences between IS-IS and OSPF. (You can find the answers from Wikipedia).
10. (2 point) Obtain the output of `/usr/sbin/ifconfig -a` and `/usr/sbin/arp -a`. Submit the printout of the output. Explain the output that you obtain.
11. (6 points)  $A, B, C, D$  and  $E$  are user nodes;  $H_1, H_2$  and  $H_3$  are hubs;  $R_1$  is a router,  $S_1$  and

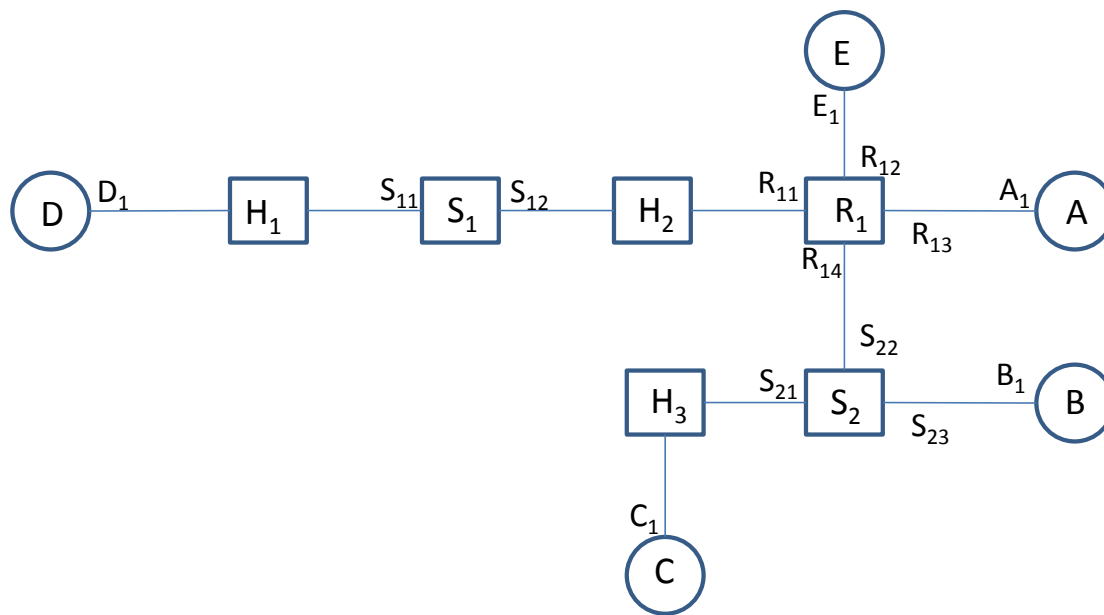

$S_2$  are switches. Assume that the router knows the routes to all nodes but the switch tables are empty, and all ARP tables are empty. If  $B$  sends a packet to  $D$ , and then  $E$  sends a packet to  $C$ , determine the entries in the switch tables of  $S_1$  and  $S_2$ ? Assume the timeout for the switch tables is very large. The MAC addresses for various interfaces are marked in the figure.