

# Concentrating Renewable Energy in Grid-Tied Datacenters

**Nan Deng**, Christopher Stewart and Jing Li  
Department of Computer Science and Engineering  
The Ohio State University

*“We are not going to solve the climate problem via efficiency –  
we must move to cleaner sources of energy.”*

Bill Wheil, Google Energy Czar  
March 2011 at Climate One Forum on Cloud Computing

## Niche market for renewable-powered computing

- 35% of the IT Managers surveyed would pay a premium for renewable-powered services. [rackspace-2009]
- Over **300,000** Facebook users petitioned for renewable-powered datacenters. [greenpeace.org-2011]
- New construction of datacenters with on-site renewable-energy sources, 7 announced in 2009 alone.
  - Renewable-energy datacenters [stewart-hotpower-2009]

- Datacenters that produce renewable energy on-site should manage their renewable-powered resources
- Renewable energy is a precious resource
  - The production of solar or wind energy is intermittent
  - The capacity of renewable energy sources may be less than the datacenter consumption
- Datacenters should concentrate renewable-energy for targeted server workloads
  - Renewable-powered computing as a service
  - Such service may attract more customers/higher prices

- Challenges facing renewable-energy concentration in datacenters
  - #1: Renewable energy is uncontrollable
  - #2: The servers that can use renewable energy produced on site are fixed by the power delivery system
  - #3: Grid-tied datacenters allow renewable energy to provide only a fraction of a server's energy needs
    - The electric grid supplies unmet power needs
  
- Contributions
  - How do grid-tied datacenters distribute renewable energy?
  - How to measure the concentration of renewable energy?
  - How do different datacenter parameters affect the concentration of renewable energy?

# Outline

- Background: Grid Ties and Grid-tied Datacenters
- *Renewable-Powered Instances*: A Metric for Renewable-Energy Concentration
- Study of Renewable-Powered Instances

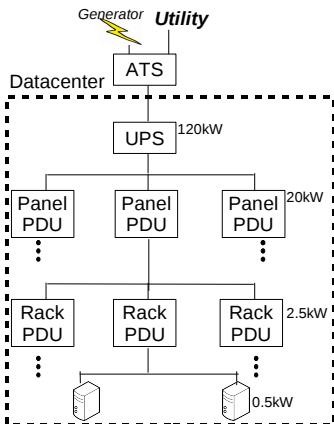

*Power delivery system in  
our CSE department's DC*

- Power delivery devices convert unstable, high voltage electricity into stable, low voltage input to servers
  - Power Delivery Unit (PDU) - Distributes power from one input to several outputs.
  - Automatic Transfer Switch (ATS) - Move servers to a backup if a primary fails
  - Uninterruptible Power supply (UPS) - Smooths transient voltage fluctuations
  
- **The power delivery system is critical to availability and rarely changes in practice**

- *Grid ties change on-site renewable energy into grid-compatible AC*
  - Inject electricity into grid powered circuits (“plug in”)
  - Datacenter uses a proportional mix of grid and on-site energy
- Most widely used device for renewable-energy integration
  - Supported by utility companies
  - Grid tie failures don't hurt DC
  - All energy produced on-site is used

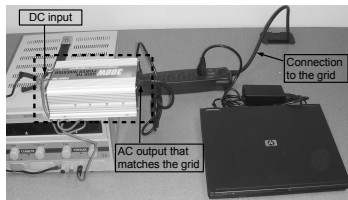

This grid tie in our lab accepts DC input from a programmable supply and powers laptop on a 120V AC circuit.

## Where should grid ties be placed in the power delivery system?

Assumption: Injected electricity flows downstream first  
(power engineering principle [bialek-1996])

No assumptions about electricity that flows upstream

- High-level placement near ATS or UPS

  - More servers downstream

  - Each server receives less renewable energy

  - Upstream flows less likely

- Low-level placement in rack PDU

  - Few servers downstream

  - Renewable energy is highly concentrated

  - Hard to account for upstream flows

  - Small grid ties are more efficient

## Where should grid ties be placed in the datacenter's power delivery system?

### Strategy #1: Place 1 grid tie at highest level

- Widely adopted in practice
- Simple & easy to approve

### Strategy #2: 1 grid tie at lower level

- Still simple & easy to approve
- Concentration tradeoff
- Extreme: Micro grid ties (300W)

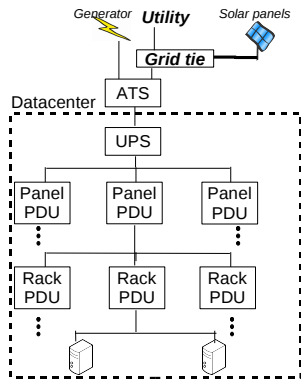

## Where should grid ties be placed in the datacenter's power delivery system?

### Strategy #3: Multiple grid ties at different levels

- Dynamically manage concentration as energy production changes
- Requires smart PDU between grid ties (we use the lowest-level grid tie that sends no electricity upstream )
- Too many grid ties increases complexity; hard to get approved

Multiple grid ties allow for high concentration under fluctuating renewable energy production

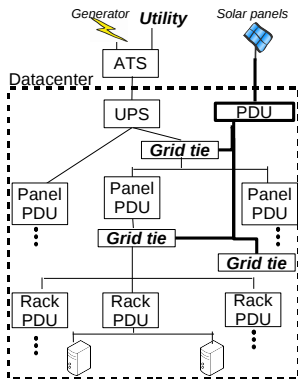

# Outline

- Background: Grid Ties and Grid-tied Datacenters
- *Renewable-Powered Instances: A Metric for Renewable-Energy Concentration*
- Study of Renewable-Powered Instances

- Compute resources (servers) separate datacenter workloads
- Grid ties may distribute renewable power to servers from different workloads
- **Problem:** Renewable-energy concentration is two dimensional
  - Percentage of server energy needs from renewable sources
  - Number of servers powered by renewable energy
- **Solution:** Define a metric that counts servers with minimum renewable power
- **Problem:** Renewable energy production *and* concentration changes over time
- **Solution:** Study instances (not servers)
  - Amazon EC2 uses a similar approach for workload changes, called *compute instances*

## Renewable-Powered Instances

- **Definition:**  $k$  Renewable-Powered Instance ( $k$ -RPI): a server that gets at least  $k\%$  of its energy needs from renewable energy in a given time period  $t$ .
- **Operational components:**  $p_i = \frac{r_i}{d_i+r_i}$ , where  $r_i$  is the amount of renewable energy to  $i$ th server;  $d_i$  is the amount of grid energy to  $i$ th server.
- Define  $k$  – RPI is a server whose  $p_i \geq k\%$  during  $t$
- See paper for a formal description in power delivery context

## Parameters that affect $k$ -RPIs in a grid-tied datacenter

- Grid-tie placement: High vs low-level strategies
- Grid-tie placement: Number of grid ties
- Minimum concentration ( $k$ )
- Renewable energy production patterns
- Server energy needs

# Outline

- Background: Grid Ties and Grid-tied Datacenters
- *Renewable-Powered Instances*: A Metric for Renewable-Energy Concentration
- Study of Renewable-Powered Instances

## Trace-Driven Simulation

- Power consumption trace - Energy usage of rack-level PDUs in **our department** from Mar. to Jun. 2010
  - We linearly scaled the production trace to produce 20% of the energy used by the datacenter
- Renewable energy production trace - 1-year (2004) trace of **wind** energy production from **Cheyenne**, WY [sap-insight]
  - The site of a well-known datacenter with on-site renewable energy [greenhousedata.com]
- 500 randomly selected grid-tie placements

## Higher RPI usually means more save on grid energy

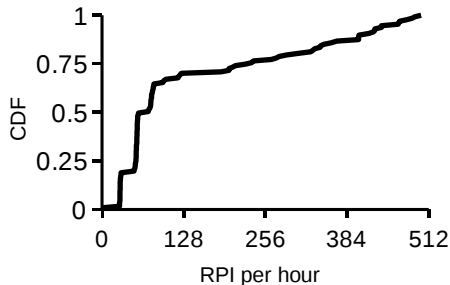
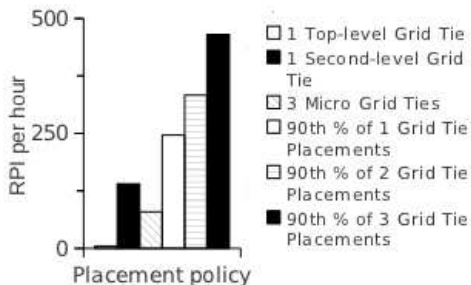

Figure: CDF of the 100% 1-hour RPI

Some placements allow datacenter managers to track 499 RPI per hour while other placements can't report any RPI. Grid-tie placement *can* affect a datacenter's ability to concentrate renewable energy.

## Multiple grid ties improved RPI



- Placing a grid tie at 2<sup>nd</sup> level instead of top level can produce high concentration without sacrificing simplicity
- Multiple grid ties improved RPI production by 1.89X

## Normalized RPI Increase (vs 100% RPI)

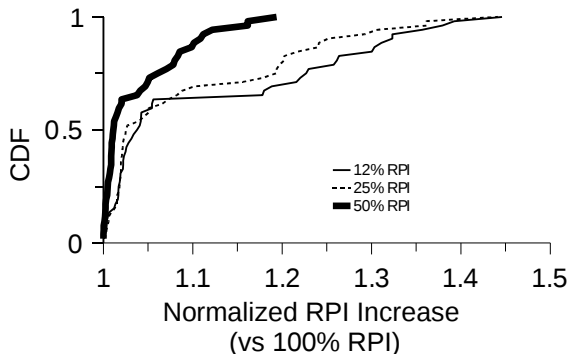

For  $k$ -RPI, decreasing  $k$  improved some placements much more than others

## Impact of Multiple Grid Ties

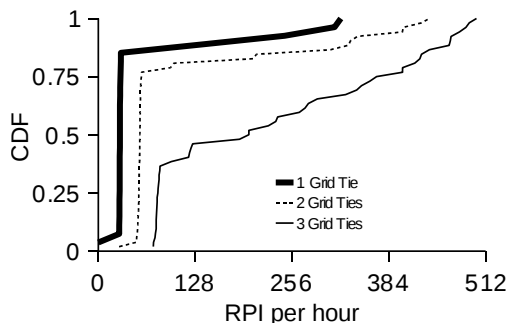

The use of multiple grid ties increases the disparity between grid-tie placements. The difference between the 90<sup>th</sup> percentile and the 10<sup>th</sup> percentile of placements with 3 grid ties was 388 RPI per hour, more than 2.5 times larger than the difference for placements with 1 grid tie.

## Related Work

- Renewable-energy datacenters have received increased attention in (computer) systems research [stewart-hotpower-2009]
- Blink [sharma-asplos-2011] and SolarCore [li-hpca-2011] developed computer systems that adapt to intermittent outages
  - These works used ATS instead of grid tie. Resources get power from only one source at a time
- Le et al. [le-igcc-2010] and Liu et al. [liu-sigmetrics-2011] adapt to changes in the energy mix from utility providers.
  - Our work considers on-site renewable sources and datacenter design, e.g., grid-tie placement

## Conclusion

- Server workloads in grid-tied datacenters are powered by a mixture of renewable and grid energy
- Renewable-Powered Instances (*RPI*) measure the concentration of renewable energy powering a workload
- Grid-tie placement can have a significant effect on the concentration of renewable energy
  - Placing a grid tie at 2<sup>nd</sup> level instead of top level can produce high concentration without sacrificing simplicity
  - Multiple grid ties improved RPI production by 1.89X